

29201 FENDER ASSEMBLY INSTRUCTIONS FOR EZ-TRI CLASSIC TRIKES

Parts List

A	Front Fender	1 PC
B	Front Fender Strut	1 PC
C	Rear Fender	2 PCS
D	Rear Fender Strut	2 PCS
E	Rear Fender Strut Clamp	2 PCS
F	M5x10mm screw	9 PCS
G	M5 nut	7 PCS
H	M6x45mm bolt	1 PC
I	M6x30mm bolt	4 PCS
J	M6 washer	3 PCS
K	M6 nut	1 PC

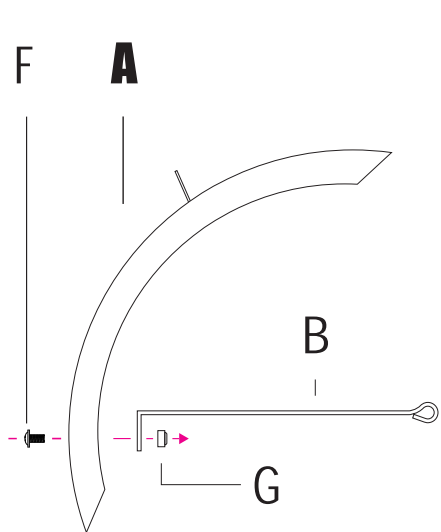
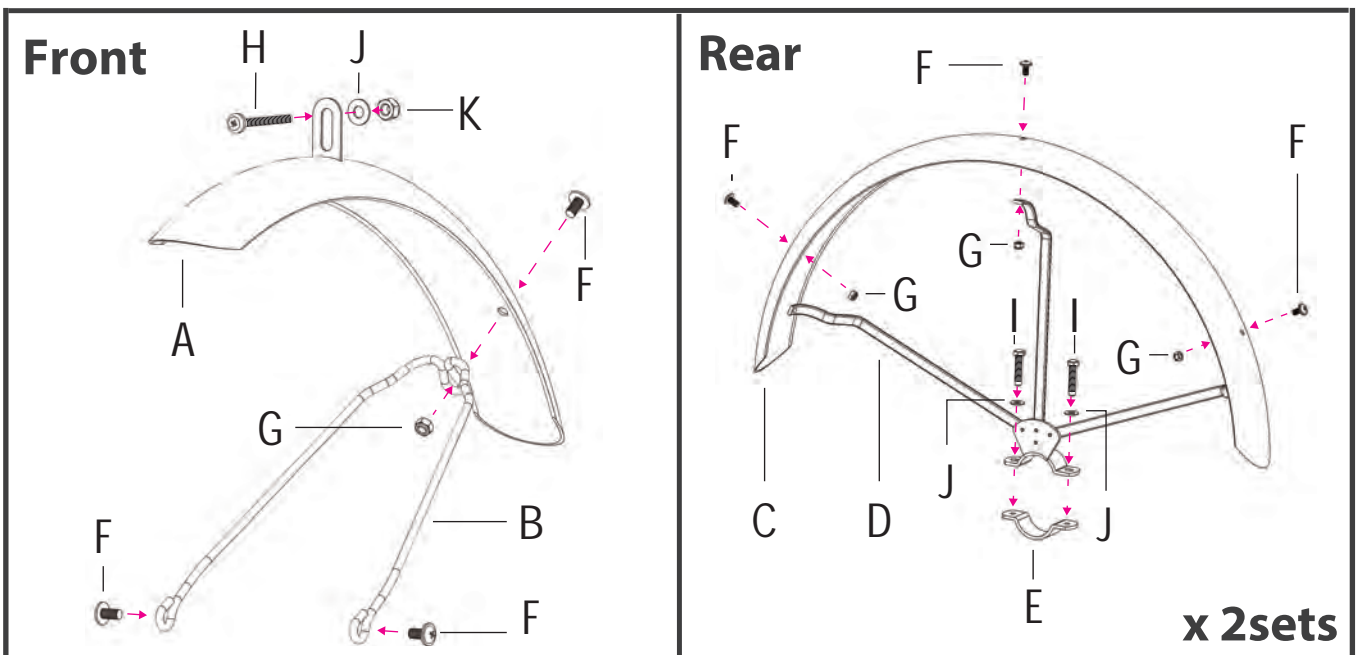

STEP 1.

Install fender strut (B) onto the front fender (A) tighten bolt (F) and nut (G).

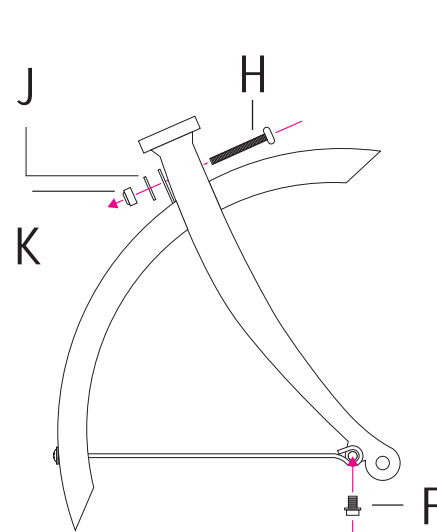

STEP 2.

Insert the front fender (A) into the fork and using the provided hardware (H, J, K) tighten.

Install fender strut (B) onto the fork dropout and secure with screw (F).

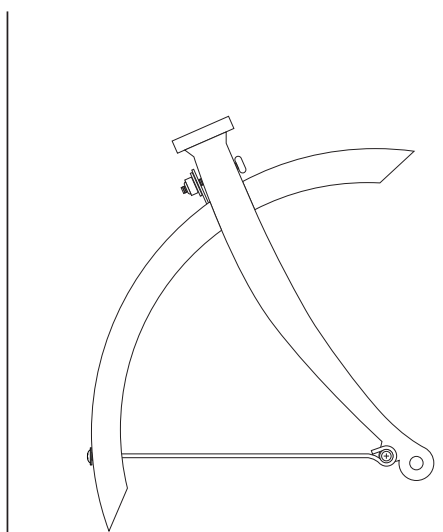

STEP 3.

Finish assembly. Make sure there is no fender interference when the tire rotates.

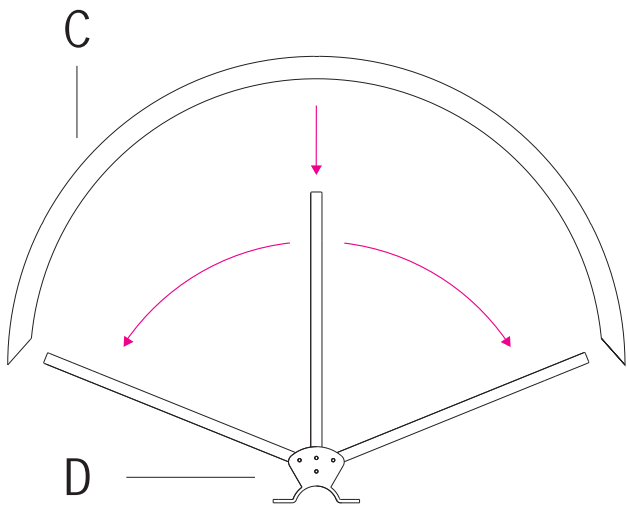

STEP 4.

Install the rear fender strut (D) onto the rear fender (C).

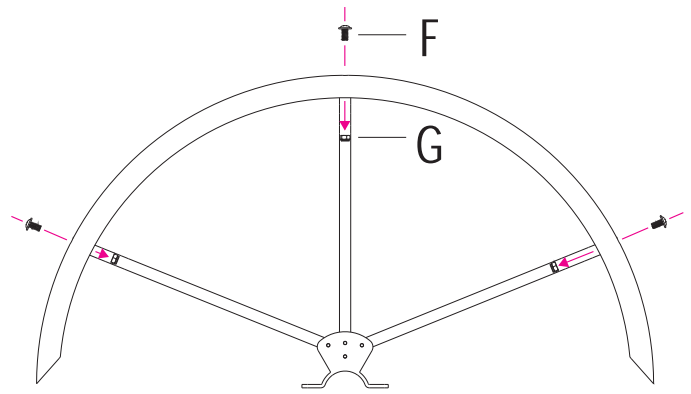

STEP 5.

Align the position of the rear fender and fender strut then tighten screws (F) and nuts (G). Same procedure on both left and right rear fenders.

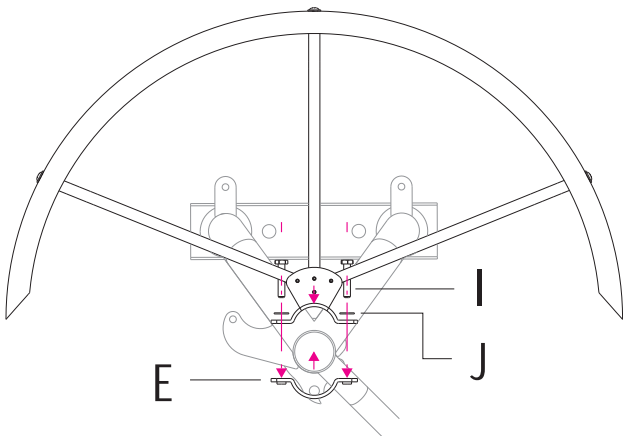

STEP 6.

Install the rear fender onto rear unit frame with rear fender strut clamp (E) and secure with bolts (I) and washers (J). Same procedure on both left and right rear fenders.

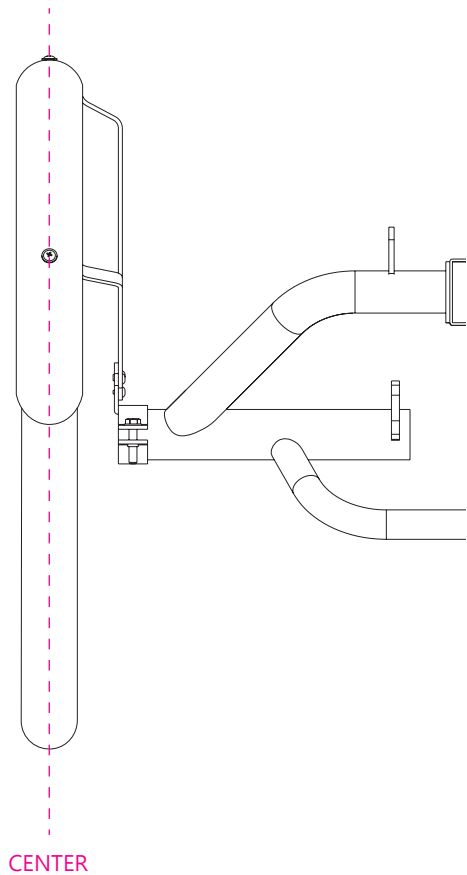

STEP 7.

Finish assembly on both sides. Adjust the fenders to be in the center position, as shown.